

## Features

**APPLICATIONS:** The Hersey MCT II Compound Magnetic Drive Meter is designed for applications where a high degree of accuracy is required over a wide range of water flow rates. Hotels, motels, institutions, schools, factories, office buildings, apartment building and commercial properties are examples of installations where domestic or process water services may have widely varying flow rates.

**CONFORMANCE TO STANDARDS:** Hersey MCT II Compound Water Meters comply with ANSI/AWWA Standard C702. Each meter is tested to ensure compliance.

**CONSTRUCTION:** Hersey Model MCTII Water Meters consist of a positive displacement measuring chamber, a turbine type measuring chamber and an automatic control valve. A nutating disc style positive displacement chamber was selected for its low flow sensitivity to accurately measure the lower flows. A rugged torrent-style turbine measuring element was selected to measure the higher flows giving the compound meter assembly a wide operating range with excellent low flow sensitivity and durability. Internal strainers protect both measuring elements and the torrent chamber is not sensitive to turbulence, eliminating any need for an external strainer in front of the meter. Separate registers are provided for each measuring chamber. The automatic valve is a weight and lever valve that opens automatically to control the point at which the mainline meter registers.

The meter is constructed so that all components are accessible without removing the meter from the line.

**REGISTERS:** Permanently sealed registers use proven magnetic drive design and the exclusive Hersey triple seal to provide clarity and error free meter reading. Internal gears in all assemblies are self-lubricating, molded plastic for long life and minimum friction. The standard dual registers include a straight reading, odometer-type, totalization display, a 360 degree test circle with center sweep hand, and a low flow indicator. The Calibrator Gear Train permits accuracy calibration. All Hersey models are available with electronic meter reading systems for increased meter reading efficiency. (See Automatic Meter Reading Equipment)

**OPERATION:** During low flow rates all water flows through the bypass section and is registered by a sensitive positive displacement nutating disc meter. When pressure loss through the bypass section approaches 4 psi, the mainline lever valve automatically opens and the mainline meter begins to register the higher flows. The bypass meter continues to register flow through the bypass section at a rate well below its maximum capacity. When flow rate decreases sufficiently, the lever valve closes and lower flows are again registered by the bypass meter alone. The registers' combined readings indicate total usage.

**MAINTENANCE:** The Hersey MCT II Meters are designed and manufactured to provide long service life.

**CONNECTIONS:** Available with integral two-bolt oval flanges on 2" size, ANSI class 150 flanges on 3" through 6" sizes (class 125 cast iron or class 150 bronze companion flanges available on request). ANSI class 125 cast iron flange on 8" size.

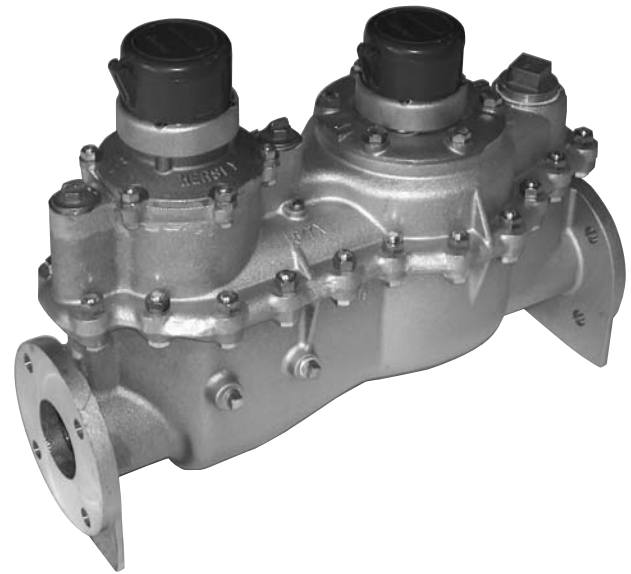

## Materials and Specifications

- **MODEL DESIGNATION** ..... MCT II (2"-8")
- **SIZES** ..... 2", 3", 4", 6" and 8"
- **STANDARDS** ..... Manufactured and tested to meet or exceed all applicable parts of ANSI/AWWA C702 Standard
- **SERVICE** .... Cold water measurement with flow in only one direction
- **OPERATING FLOW RANGE** ..... See Chart on page 5.2
- **ACCURACY** ..... See Chart on page 5.2
- **MAXIMUM PRESSURE LOSS** ..... See Chart on page 5.2
- **MAXIMUM WORKING PRESSURE** ..... 150 PSI
- **TEMPERATURE RANGE** ..... 33° F to 100° F water temperature
- **MEASURING ELEMENTS** ..... Torrent Wheel and Nutating Disc
- **REGISTER TYPE** .... Permanently sealed, straight reading, magnetic drive with low flow indicator. Remote reading units optional.
- **STRAINERS** ..... Internal strainers protect both measuring elements eliminating the need for an external strainer
- **METER CONNECTIONS** ..... 2" size available with two bolt flanged ends 3" thru 6" ANSI class 150 flanges, 8" ANSI class 125.
- **MATERIALS** ..... Maincase - (2"-6") bronze UNSC84400, (8") cast iron; Magnets - Ceramic; Strainer - thermoplastic; Casing bolts - steel ANSI B18; By-pass chamber - (2"-4") three piece thermoplastic, (6" & 8") bronze UNSC84400; Mainline torrent - (2" & 3") thermoplastic, (4"-8") bronze UNSC84400.
- **OPTIONS** ..... AMR Reading Systems; Trim Valves

\* 8" size is different from 2"-6" sizes in that it is cast iron with two-piece body and external bypass.

# Model MCT II

Compound Magnetic Drive Meters  
 Sizes 2", 3", 4", 6" and 8"\*

## Meter Registration

Meter Size	Initial Dial*		Capacity		Initial Dial*		Capacity	
	Mainline	Bypass	Mainline	Bypass	Mainline	Bypass	Mainline	Bypass
2"	100 Gallons	10 Gallons	100 Million	10 Million	10 Cubic Feet	1 Cubic Feet	10 Million	1 Million
3"	100 Gallons	10 Gallons	100 Million	10 Million	10 Cubic Feet	1 Cubic Feet	10 Million	1 Million
4"	1000 Gallons	10 Gallons	1 Billion	10 Million	100 Cubic Feet	1 Cubic Feet	100 Million	1 Million
6"	1000 Gallons	100 Gallons	1 Billion	100 Million	100 Cubic Feet	10 Cubic Feet	100 Million	10 Million
8"	1000 Gallons	100 Gallons	1 Billion	100 Million	100 Cubic Feet	10 Cubic Feet	100 Million	10 Million

## Flow Characteristics

Meter Size	Typical Low Flow (95% Minimum)	Typical Operating Range (100% ± 3%)	Maximum Continuous Operation
2"	1/4 GPM	1 to 160 GPM	80 GPM
3"	1/2 GPM	4 to 320 GPM	160 GPM
4"	3/4 GPM	6 to 500 GPM	250 GPM
6"	1-1/2 GPM	10 to 1000 GPM	500 GPM
8"	2 GPM	16 to 1600 GPM	800 GPM

## Performance\*

### Head loss - 2"

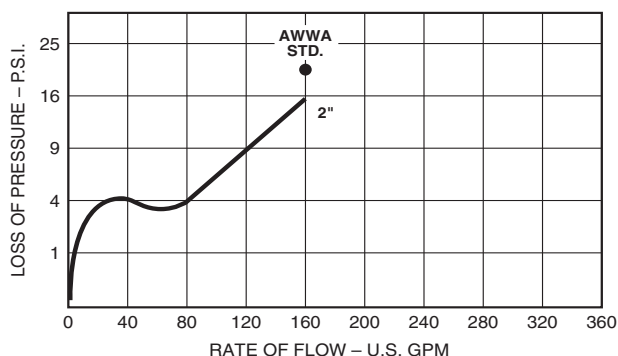

### Accuracy - 2"

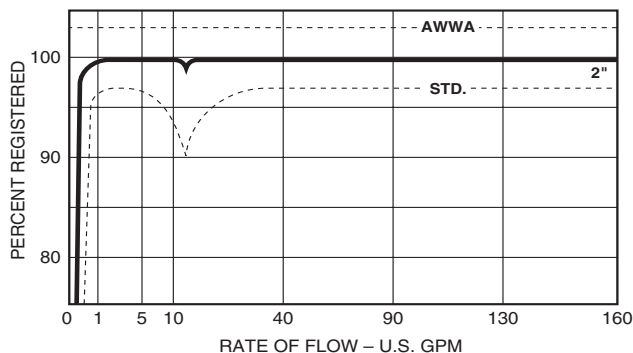

### Head loss - 3"

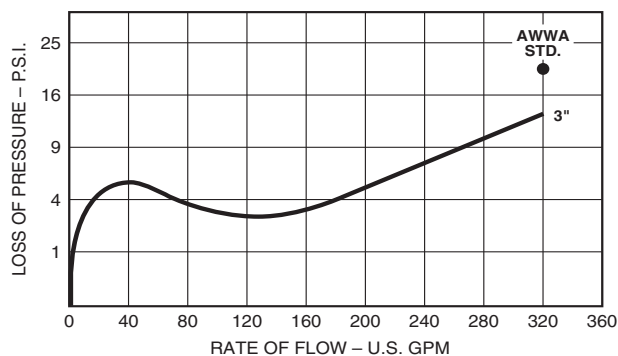

### Accuracy - 3"

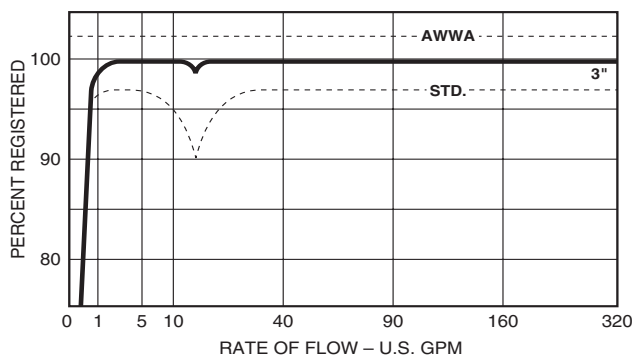

## Performance\*

### Head loss - 4"

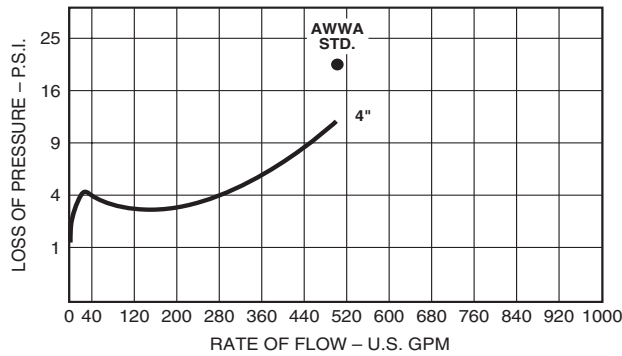

### Accuracy - 4"

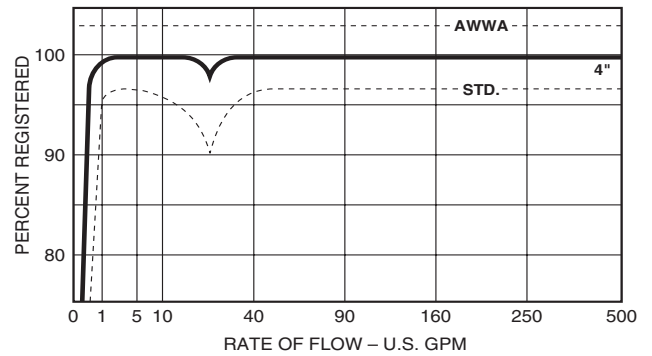

### Head loss - 6"

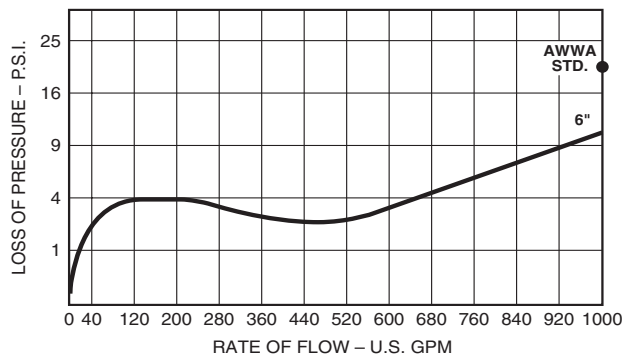

### Accuracy - 6"

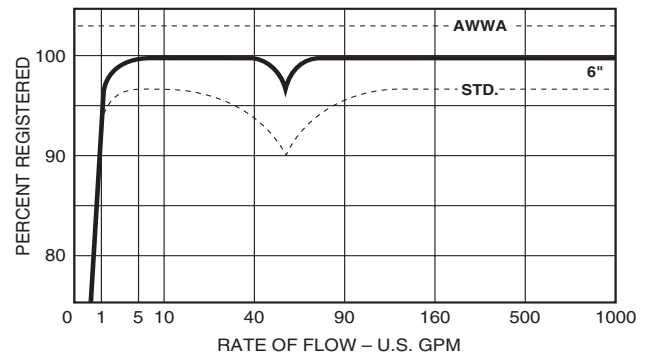

### Head loss - 8"\*\*\*

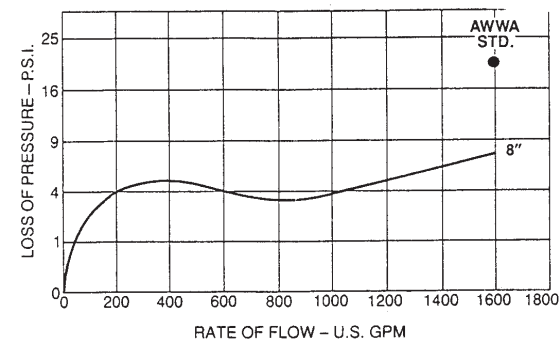

### Accuracy - 8"\*\*\*

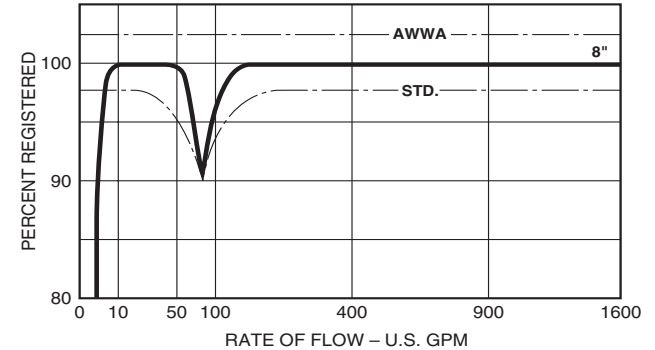

\*Performance curves are typical only and not a guarantee of performance.

\*\* 8" size is different from 2"-6" sizes in that it is cast iron with two-piece body and external bypass.

## Dimensions and Weights

Meter Size	2"	3"	4"	6"	8"
<b>Dimension</b>					
A	17"	24"	29"	36-1/2"	55-1/4"
B	15-1/4"	19-3/4"	23"	29"	29-1/2"
C	2-1/4"	4"	5"	6"	7-1/2"
D - Width	8-1/4"	10-1/2"	12-3/4"	17"	30"
Net weight	77	160	270	645	1564

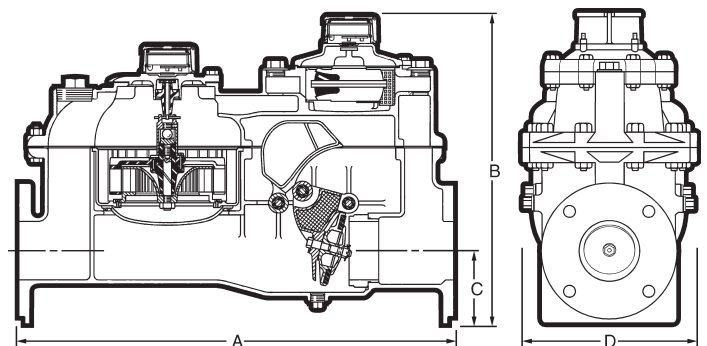

Note: Weights are in pounds and are approximate.